

S1=S4=S13=S16=S21

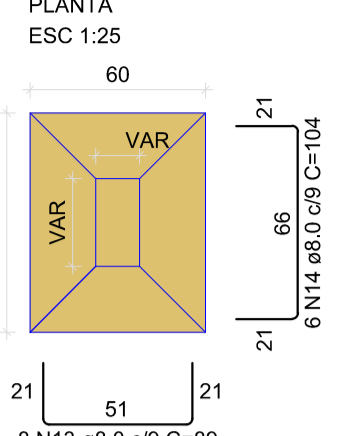

Solo com capacidade de suporte > 1.50 kgf/cm²
Solo compactado sobre a sapata
peso específico > 1600.00 kg/m³

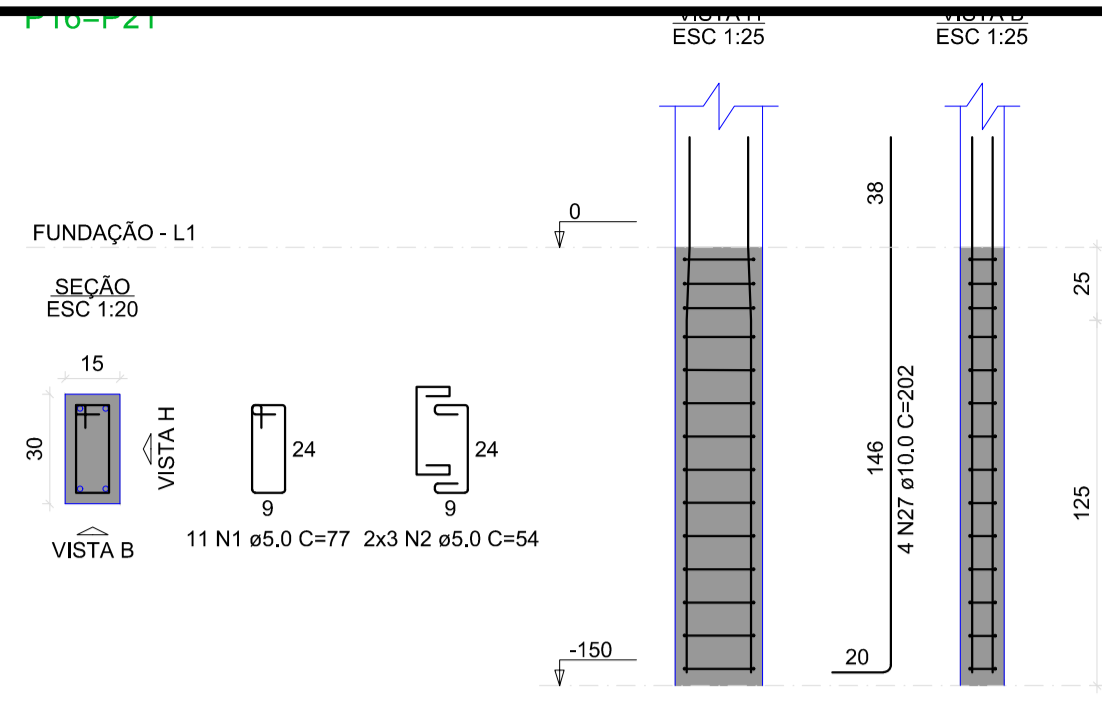
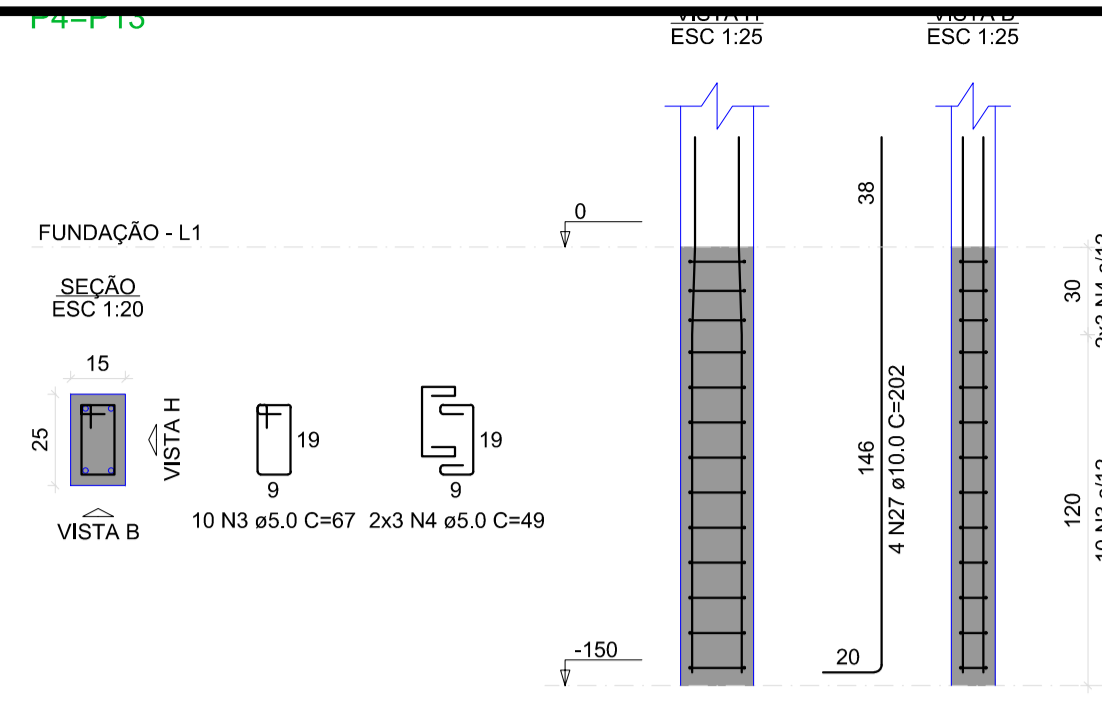
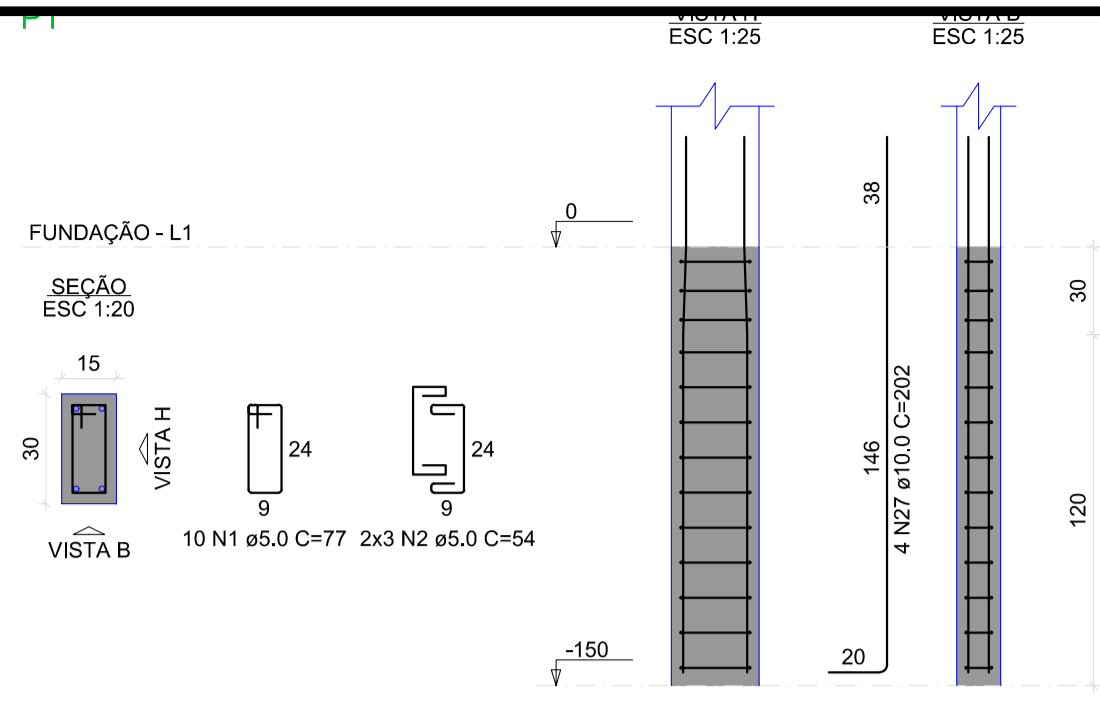
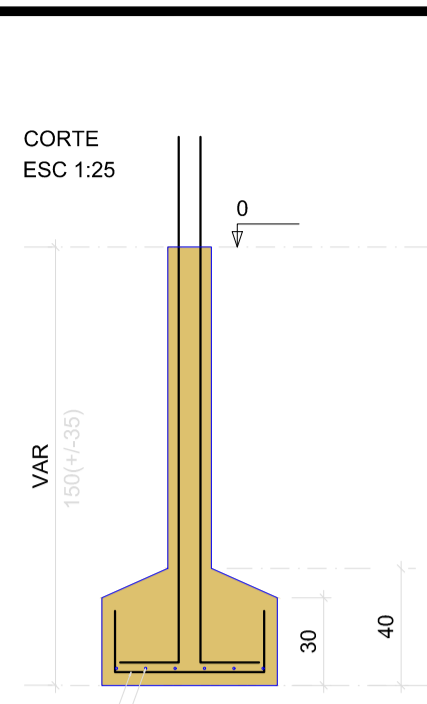

S18

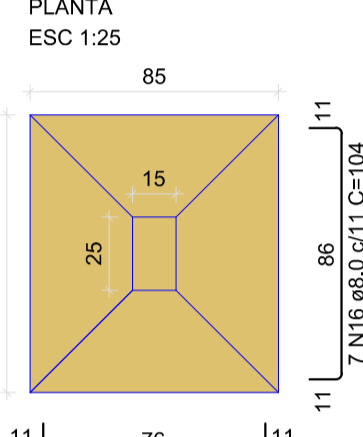

Solo com capacidade de suporte > 1.50 kgf/cm²
Solo compactado sobre a sapata
peso específico > 1600.00 kg/m³

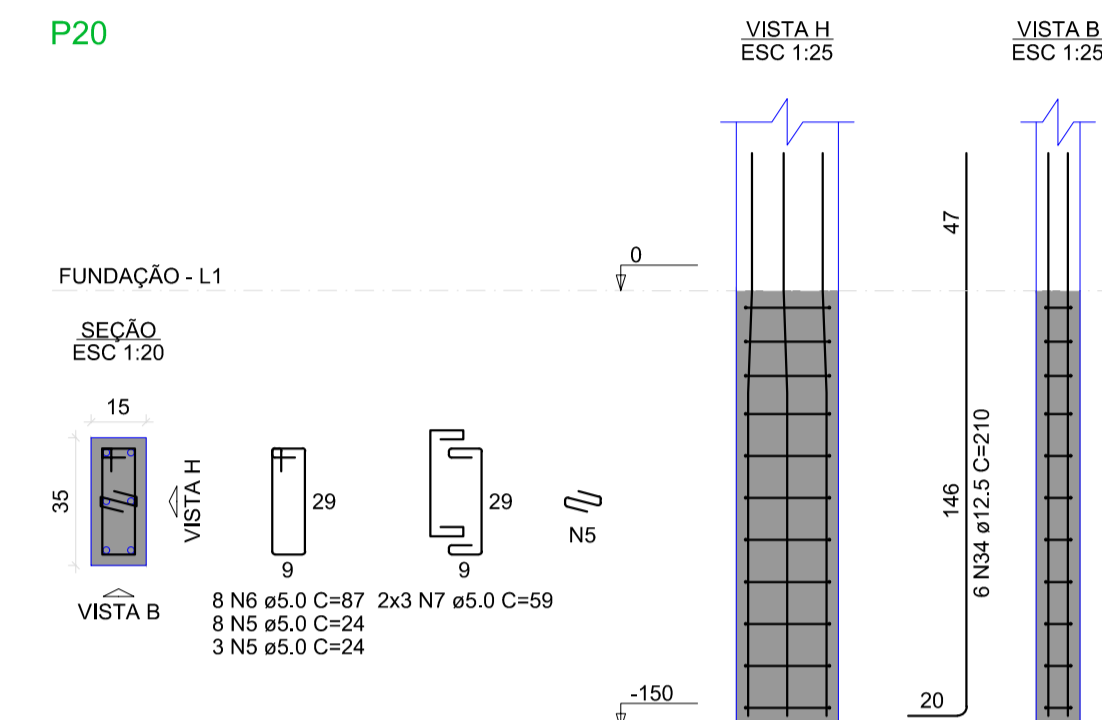
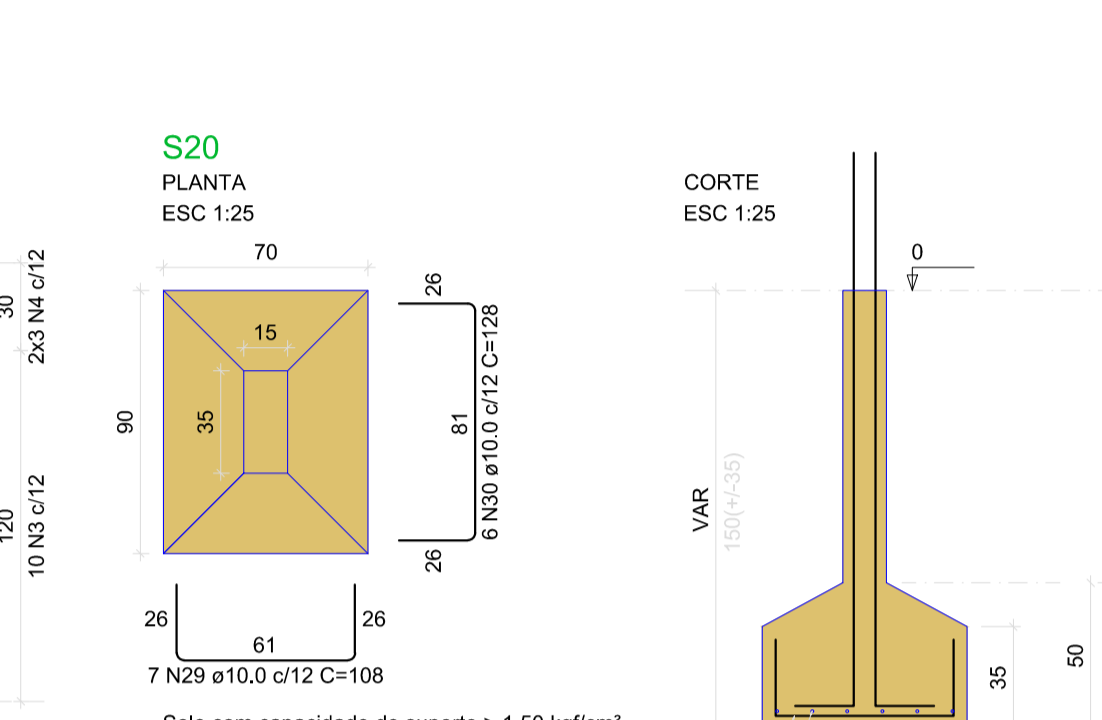
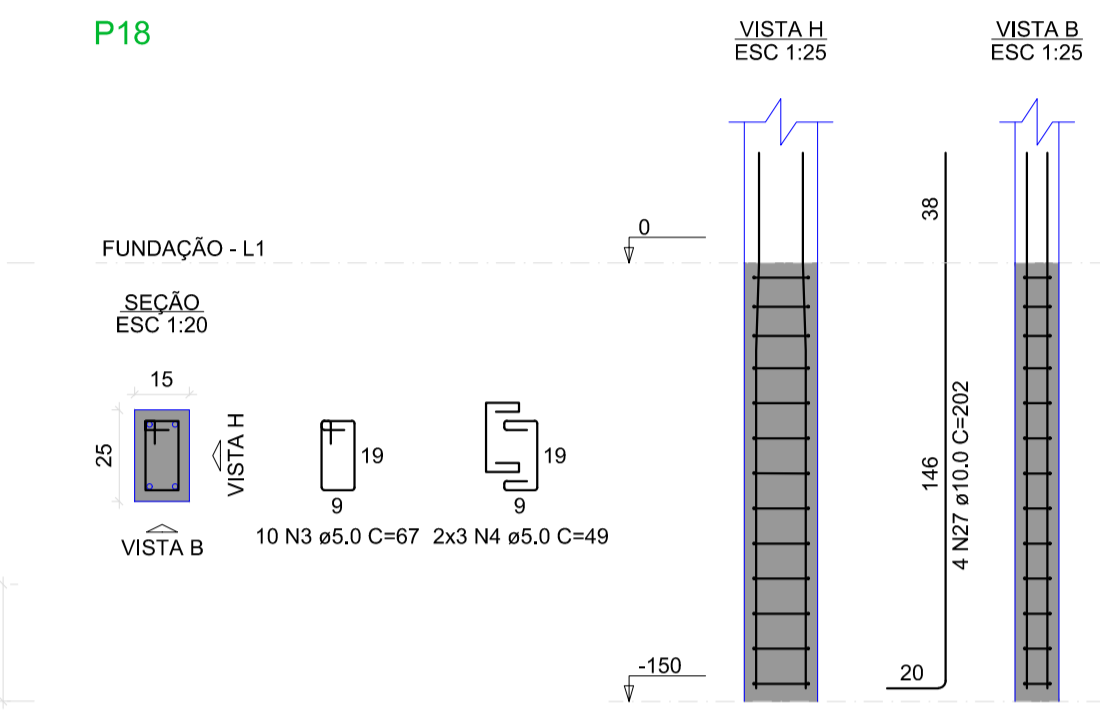
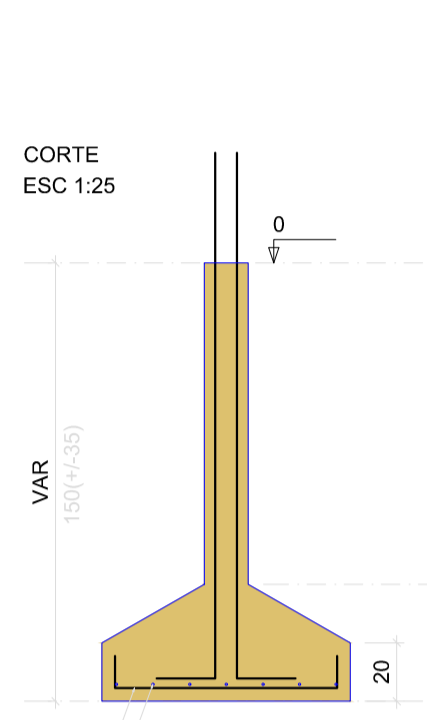

S26

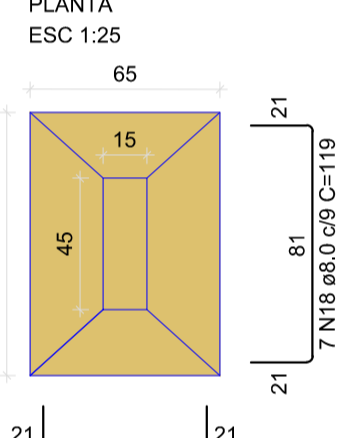

Solo com capacidade de suporte > 1.50 kgf/cm²
Solo compactado sobre a sapata
peso específico > 1600.00 kg/m³

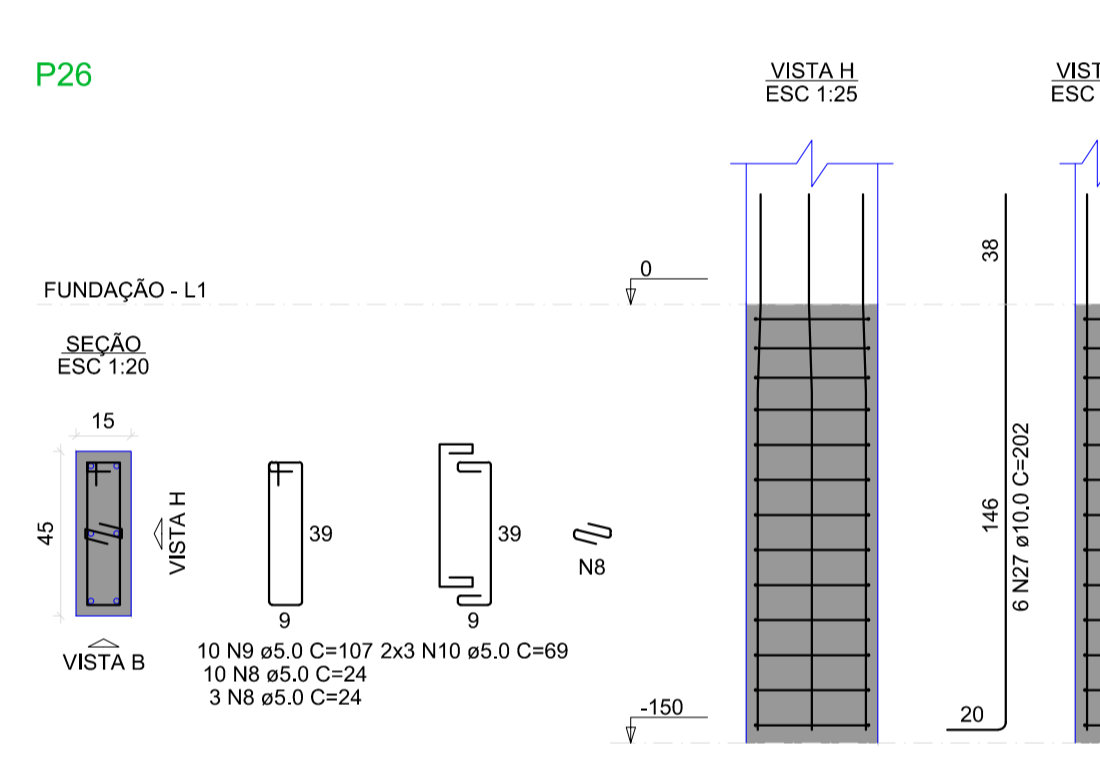
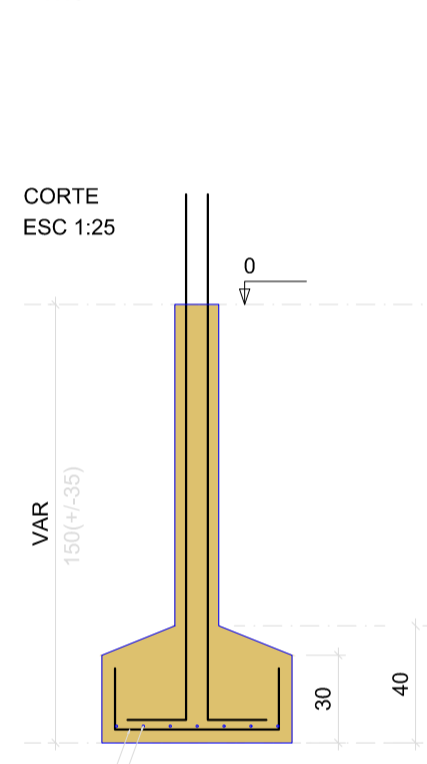

S29=S30=S34

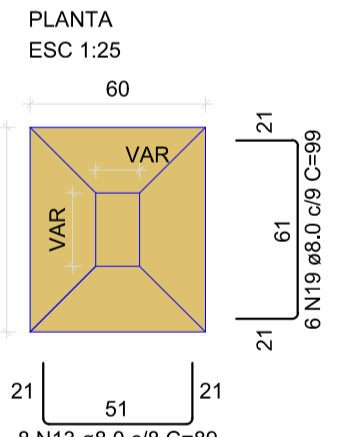

Solo com capacidade de suporte > 1.50 kgf/cm²
Solo compactado sobre a sapata
peso específico > 1600.00 kg/m³

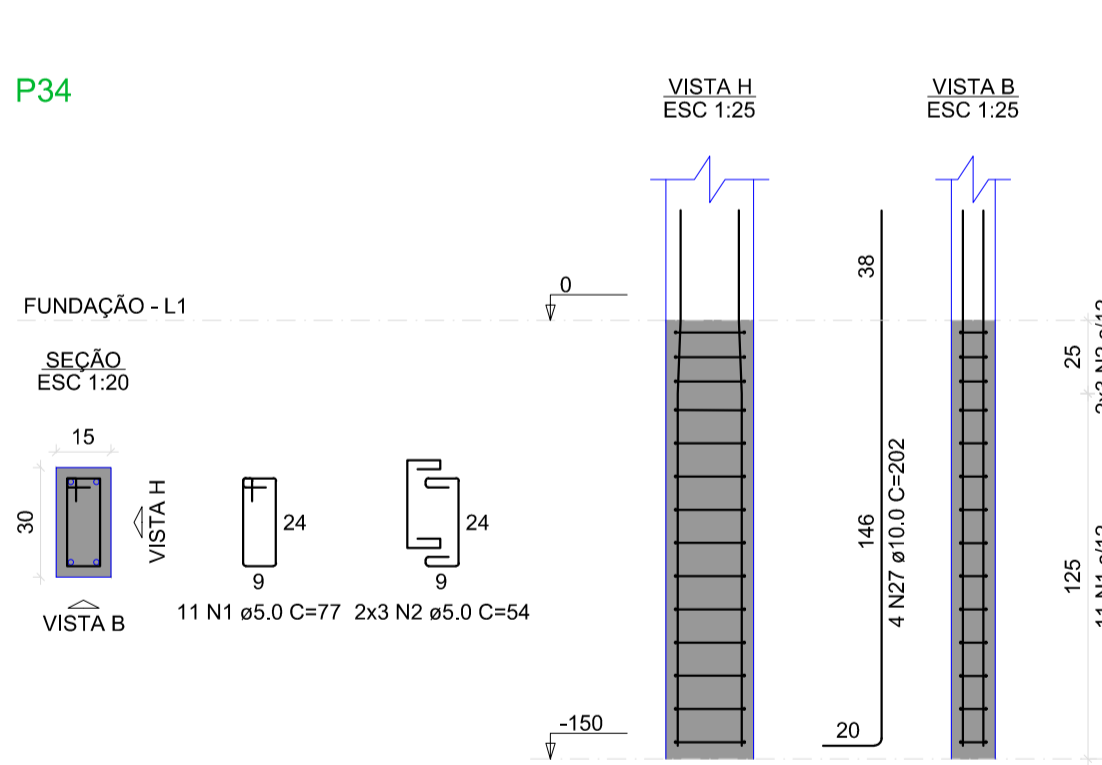
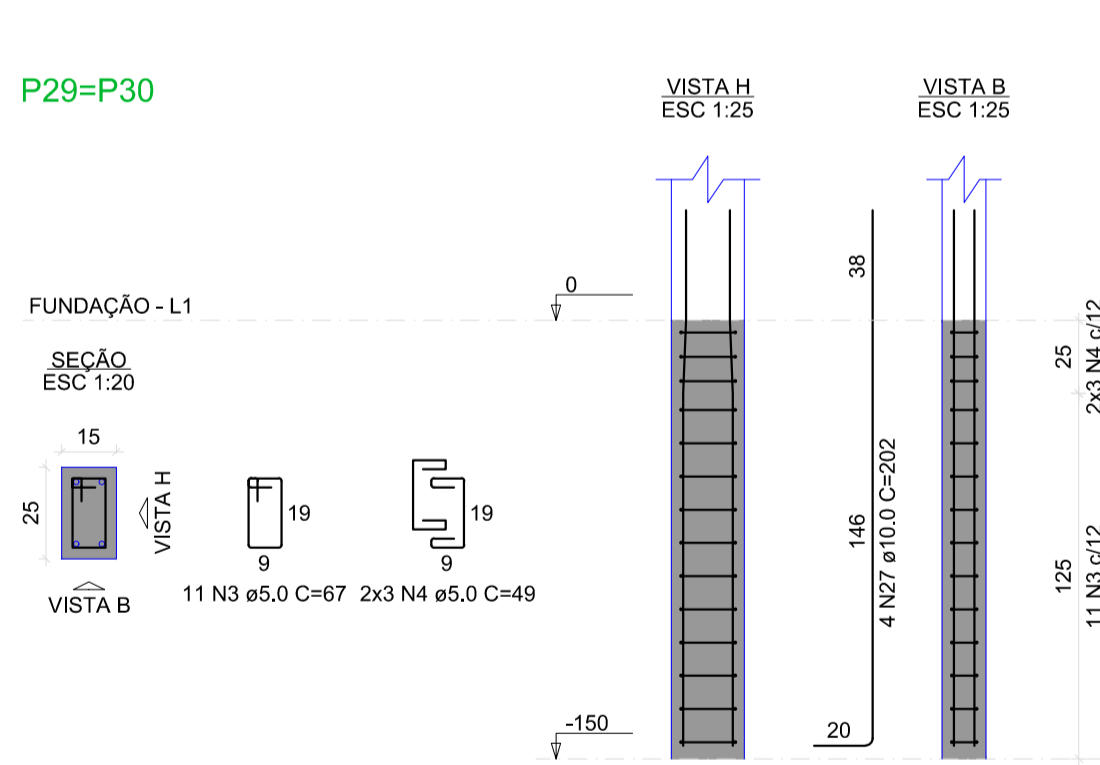
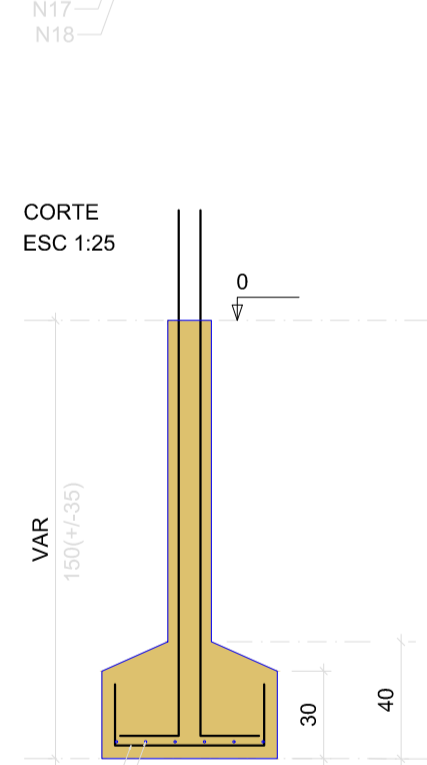

S31

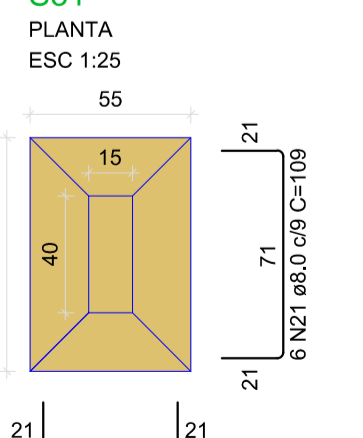

Solo com capacidade de suporte > 1.50 kgf/cm²
Solo compactado sobre a sapata
peso específico > 1600.00 kg/m³

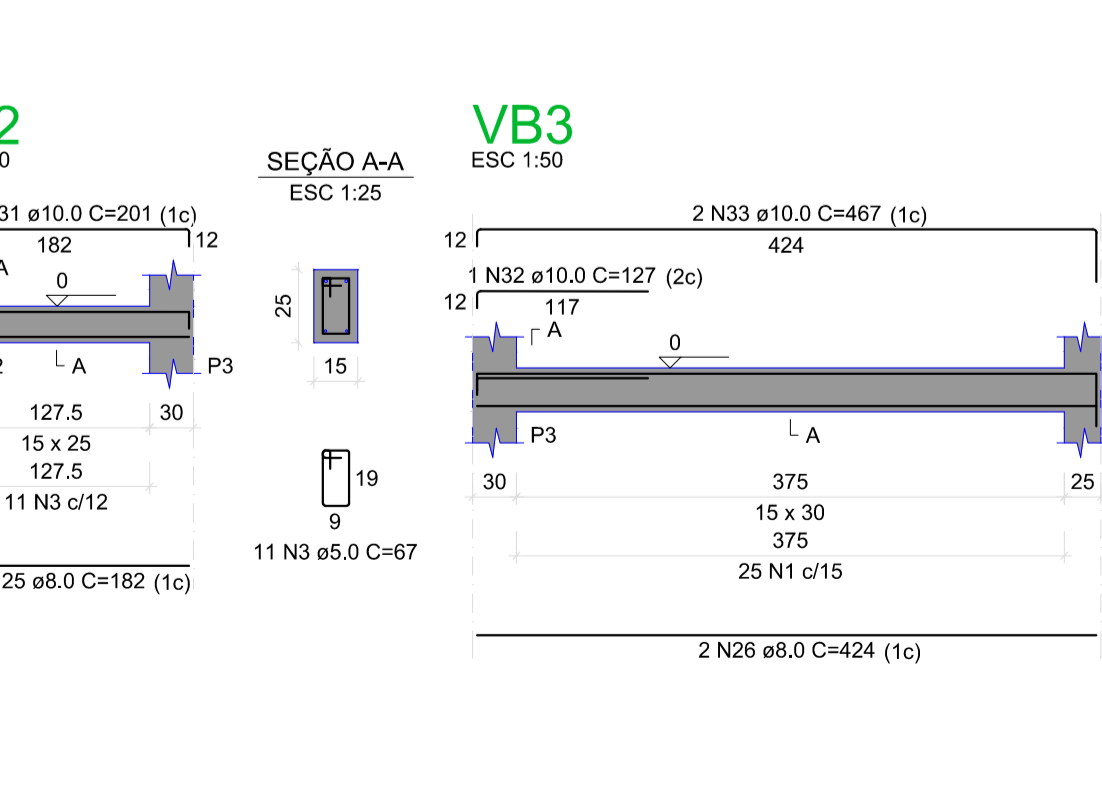
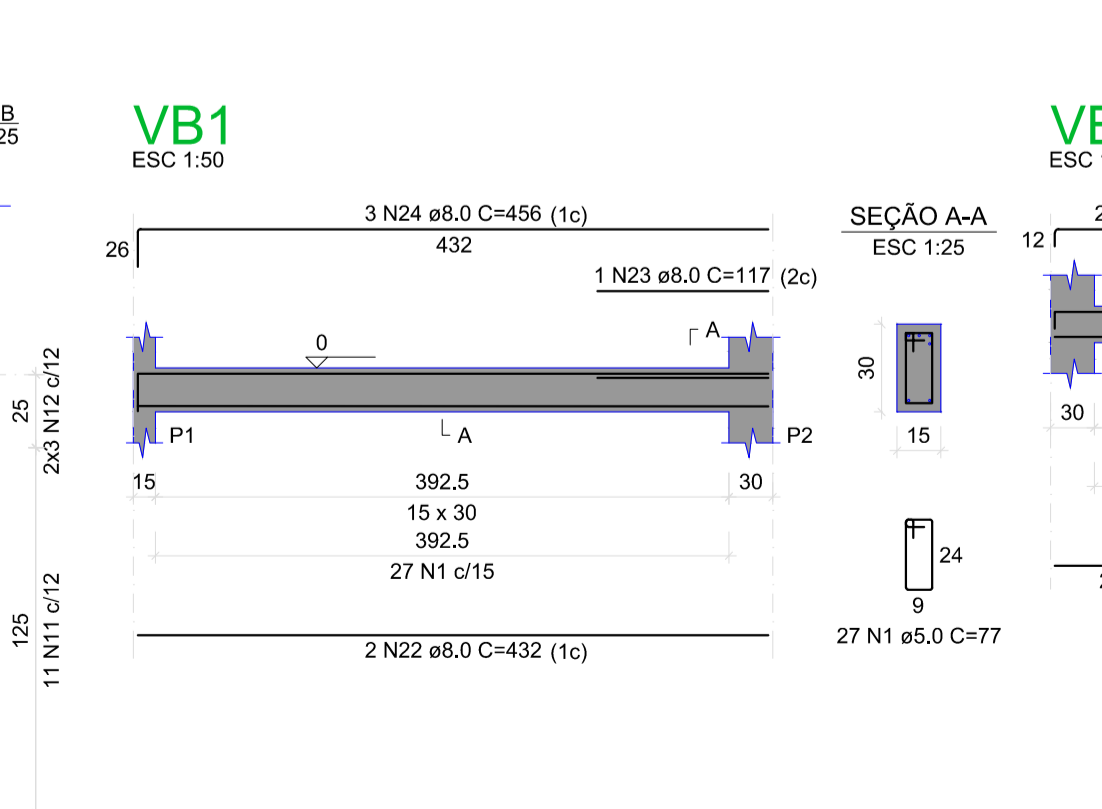
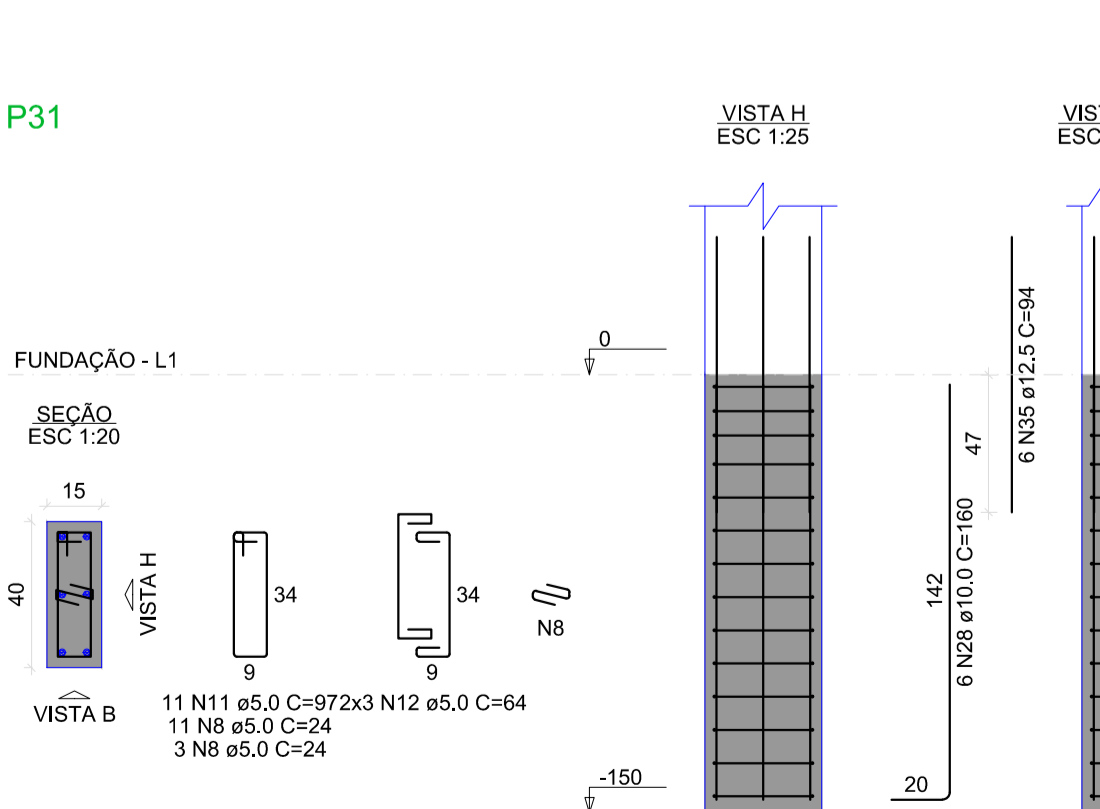
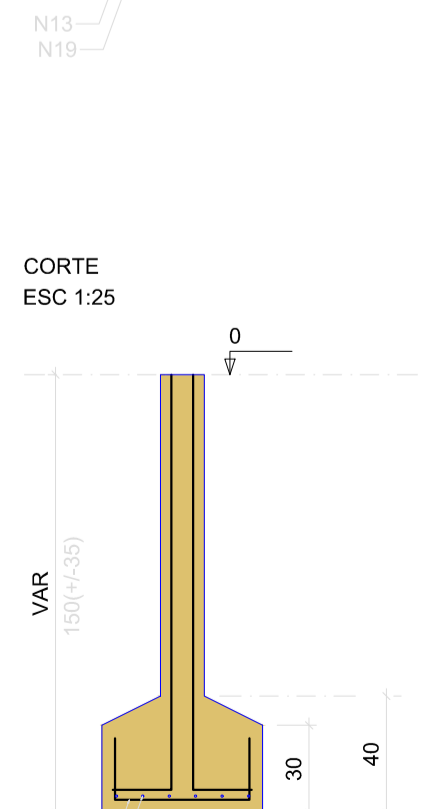

RELAÇÃO DO AÇO

AÇO	N	DIAM (mm)	QUANT	C.UNIT (cm)	C.TOTAL (cm)
CA80	1	5.0	95	77	7315
	2	5.0	24	54	1296
	3	5.0	63	67	4221
	4	5.0	30	49	1470
	5	5.0	11	24	264
	6	5.0	8	87	696
	7	5.0	7	59	364
	8	5.0	27	24	648
	9	5.0	10	107	1070
	10	5.0	6	69	414
	11	5.0	11	97	1067
	12	5.0	6	64	384
	13	8.0	64	89	5696
	14	8.0	30	104	3120
	15	8.0	9	94	846
	16	8.0	7	104	728
	17	8.0	9	94	846
	18	8.0	7	119	833
	19	8.0	18	99	1782
	20	8.0	9	84	756
	21	8.0	6	109	654
	22	8.0	2	432	864
	23	8.0	1	117	117
	24	8.0	3	456	1368
	25	8.0	2	182	364
	26	8.0	2	424	848
	27	10.0	42	202	8484
	28	10.0	6	160	960
	29	10.0	7	108	756
	30	10.0	6	128	768
	31	10.0	2	201	402
	32	10.0	1	127	127
	33	10.0	2	467	934
	34	12.5	6	210	1260
	35	12.5	6	94	564

RESUMO DO AÇO

AÇO	DIAM (mm)	C.TOTAL (m)	PESO + 10% (kg)
CA50	8.0	188.2	81.7
	10.0	124.3	84.3
	12.5	18.2	19.3
	5.0	192	32.6
PESO TOTAL (kg)			
CA50		185.3	
CA80		32.6	

Volume de concreto (C-25) = 3.35 m³
Área de forma = 34.05 m²

PREFEITURA	CREA						
BOMBEIRO OU NATURATINS							
PROJETO:	FOLHA:						
PROJETO ESTRUTURAL							
2/7							
<p>OBRA: CENTRO DE REFERÊNCIA DE ASSISTÊNCIA SOCIAL- CRAS PROPRIETÁRIO: PREFEITURA MUNICIPAL DE SÃO BENTO DO TOCANTINS CNPJ: 25.063.983/0001-36 ENDEREÇO: TRAVESSA MANOEL RODRIGUES TOCANTINS, - CENTRO</p>							
QUADRO DE ÁREAS	<table border="1"> <tr> <td>ASSINATURA PROPRIETÁRIO</td> <td>PREFEITURA MUNICIPAL DE SÃO BENTO DO TOCANTINS</td> </tr> <tr> <td>AUTOR PROJETO 315.184/D-TO ENGENHEIRO CIVIL</td> <td>FRANCISCO AUGUSTO DA S. VALENTIN</td> </tr> <tr> <td>RESP. TÉCNICO 315.184/D-TO ENGENHEIRO CIVIL</td> <td>FRANCISCO AUGUSTO DA S. VALENTIN</td> </tr> </table>	ASSINATURA PROPRIETÁRIO	PREFEITURA MUNICIPAL DE SÃO BENTO DO TOCANTINS	AUTOR PROJETO 315.184/D-TO ENGENHEIRO CIVIL	FRANCISCO AUGUSTO DA S. VALENTIN	RESP. TÉCNICO 315.184/D-TO ENGENHEIRO CIVIL	FRANCISCO AUGUSTO DA S. VALENTIN
ASSINATURA PROPRIETÁRIO	PREFEITURA MUNICIPAL DE SÃO BENTO DO TOCANTINS						
AUTOR PROJETO 315.184/D-TO ENGENHEIRO CIVIL	FRANCISCO AUGUSTO DA S. VALENTIN						
RESP. TÉCNICO 315.184/D-TO ENGENHEIRO CIVIL	FRANCISCO AUGUSTO DA S. VALENTIN						
ESCALA:	DESENHO: FRANCISCO AUGUSTO DATA: FEVEREIRO DE 2020						
CONTEÚDO: DETALHES DA FUNDAÇÃO							